



Zoning Resolution

THE CITY OF NEW YORK

Eric Adams, Mayor

CITY PLANNING COMMISSION

Daniel R. Garodnick, Chair

81-262 - Maximum height of front wall at the street line

File generated by <https://zr.planning.nyc.gov> on 10/14/2024

81-262 - Maximum height of front wall at the street line

LAST AMENDED

5/13/1982

(a) General provisions

The front wall of a #building# at the #street line# shall not exceed the height limit applying along the #street# on which it fronts. Maximum front wall heights at the #street line# vary with the width of the #street# on which the wall fronts, as follows:

#Street# Width (in feet)	Maximum Front Wall Height at #Street Line# (in feet)
60 or less	90
75 or 80	120
100 or more	150

(b) Special provisions for #corner lots#

For a #corner lot# with frontage on #streets# of different widths, the maximum front wall height at the #street line# of the narrower #street# may be increased above that indicated in paragraph (a) in accordance with either one of the following rules:

Rule 1:

The maximum front wall height at the #street line# for the wider #street# may extend up to 100 feet from the corner along the #street line# of the narrower #street#; or

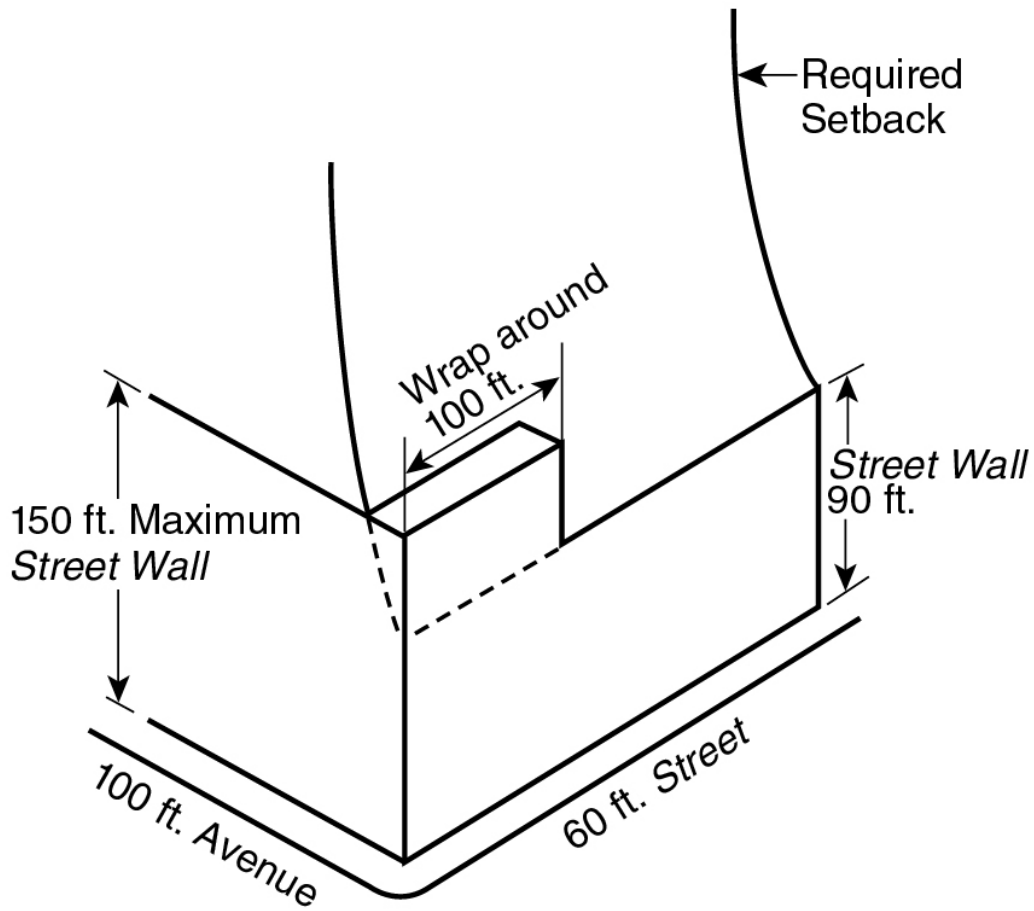

SPECIAL RULE 1 FOR CORNER LOTS

(81-262b.1)

Rule 2:

For any length of frontage from the corner along the narrower #street#, a maximum height for such length of frontage may apply, which shall be the weighted average of (1) the height permitted under Rule 1 for the first 100 feet from the corner, and (2) the standard height limit for front walls on the narrower #street# for the remainder of the frontage. (See illustration of Special Rules for #Corner Lots#)

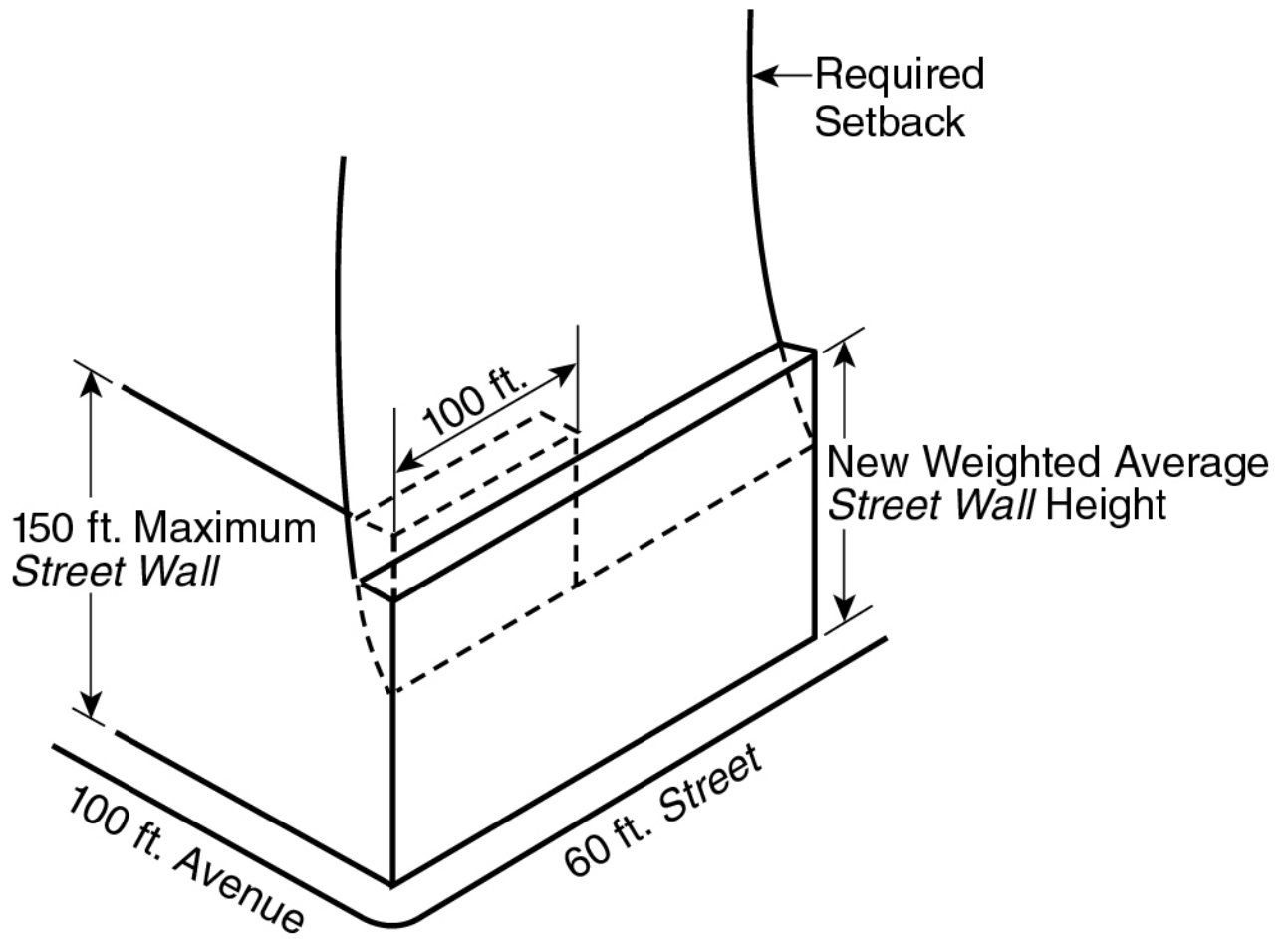

SPECIAL RULE 2 FOR CORNER LOTS

(81-262b.2)