



Zoning Resolution

THE CITY OF NEW YORK

Eric Adams, Mayor

CITY PLANNING COMMISSION

Daniel R. Garodnick, Chair

23-641 - Front setbacks

File generated by <https://zr.planning.nyc.gov> on 4/23/2024

23-641 - Front setbacks

LAST AMENDED

3/22/2016

R6 R7 R8 R9 R10

In the districts indicated without a letter suffix, if the front wall or other portion of a #building or other structure# is located at the #street line# or within the #initial setback distance# set forth in the following table, the height of such front wall or other portion of a #building or other structure# shall not exceed the maximum height above the #street line# set forth in the table. Above such specified maximum height and beyond the #initial setback distance#, the #building or other structure# shall not penetrate the #sky exposure plane# set forth in the table, except as otherwise provided in Sections [23-62](#) (Permitted Obstructions) or [23-65](#) (Tower Regulations).

MAXIMUM HEIGHT OF FRONT WALL AND REQUIRED FRONT SETBACKS

#Initial Setback Distance# (in feet)		Maximum Height of a Front Wall or other portion of a #Building or Other Structure# within the #Initial Setback Distance#	#Sky Exposure Plane#				
			Height above #Street Line# (in feet)	Slope over #Zoning Lot# (expressed as a ratio of vertical distance to horizontal distance)			
On #Narrow Street#	On #Wide Street#			On #Narrow Street#		On #Wide Street#	
			Vertical Distance	Horizontal Distance	Vertical Distance	Horizontal Distance	
R6 or R7 Districts							
20	15	60 feet or six #stories#, whichever is less	60	2.7	to 1	5.6	to 1
R8 R9 or R10 Districts							
20	15	85 feet or nine #stories#, whichever is less	85	2.7	to 1	5.6	to 1

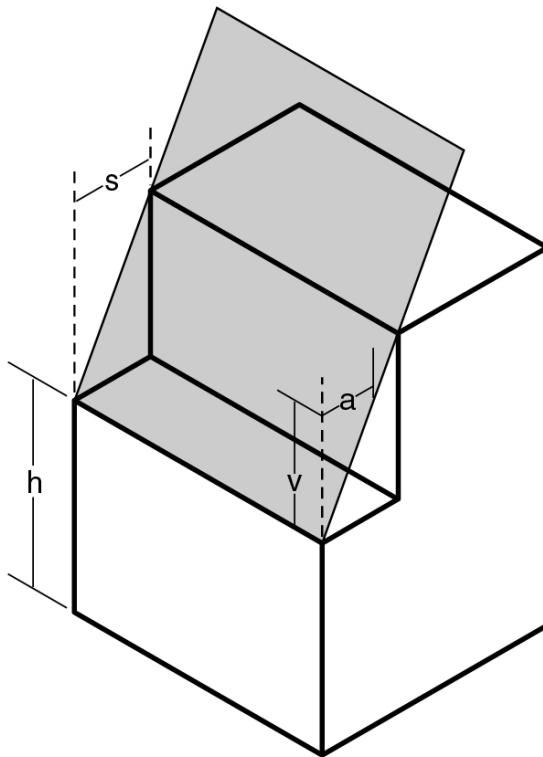

a - Horizontal distance

s - *Initial setback distance*

h - Height of *sky exposure plane*
above *street line*

v - Vertical distance

 *Sky Exposure Plane*

SKY EXPOSURE PLANE

R6 R7 R8 R9 R10 Districts

(23-641, 24-522, 33-432, 43-43)