



Zoning Resolution

THE CITY OF NEW YORK

Eric Adams, Mayor

CITY PLANNING COMMISSION

Daniel R. Garodnick, Chair

118-30 - STREET WALL, HEIGHT AND SETBACK REGULATIONS

File generated by <https://zr.planning.nyc.gov> on 12/22/2024

118-30 - STREET WALL, HEIGHT AND SETBACK REGULATIONS

LAST AMENDED

12/6/2023

The location and height above #curb level# of the #street wall# of any #development# or #enlargement# shall be as shown in the District Plan (Appendix A). However, if a #development# or #enlargement# is adjacent to one or more existing #buildings# fronting on the same #street line#, the #street wall# of such #development# or #enlargement# shall be located neither closer to nor further from the #street line# than the front wall of the adjacent #building# which is closest to the same #street line#.

#Street wall# recesses are permitted below the level of the second #story# ceiling for subway stair entrances required under Section [118-50](#) (OFF STREET RELOCATION OF A SUBWAY STAIR WITHIN THE SPECIAL UNION SQUARE DISTRICT). Such recesses shall be no longer than 15 feet and no deeper than eight feet or the width or length of the relocated subway stair, whichever is greater.

#Street wall# recesses are also permitted below the level of the second #story# ceiling for #building# or store entrances only.

A #sky exposure plane# of 2.5 to 1 shall begin at a height above #curb level# of 125 feet on all #streets# within the Special District, except that on a #narrow street# beyond 100 feet from any #street line# opposite a #public park# or from the intersection of such #narrow street# with a #wide street#, the #sky exposure plane# shall begin at a height above #curb level# of 85 feet.

No #development# or #enlargement# shall penetrate such #sky exposure plane# except pursuant to Section [33-45](#) (Tower Regulations). However, Section [33-45](#) shall not be applicable to any portion of a #building# located within 100 feet of a #street line# opposite a #public park#.

However, #energy infrastructure equipment# and #accessory# mechanical equipment shall be permitted obstructions above such height limits, subject to the provisions of Section [33-42](#).

118-31 - Modification of Street Wall Requirements

LAST AMENDED

2/2/2011

- (a) On a #zoning lot# where there is an existing #building# to remain, the requirements governing height and location of #street walls# shall not apply within a volume defined by the rear wall of the existing #building# (W2), the #front lot line# (W1), the prolongations of the side walls (L) and a height of 125 feet above #curb level#.

If, after January 10, 1985, any demolition or destruction occurs within the volume defined, the requirements governing #street wall# height shall apply.

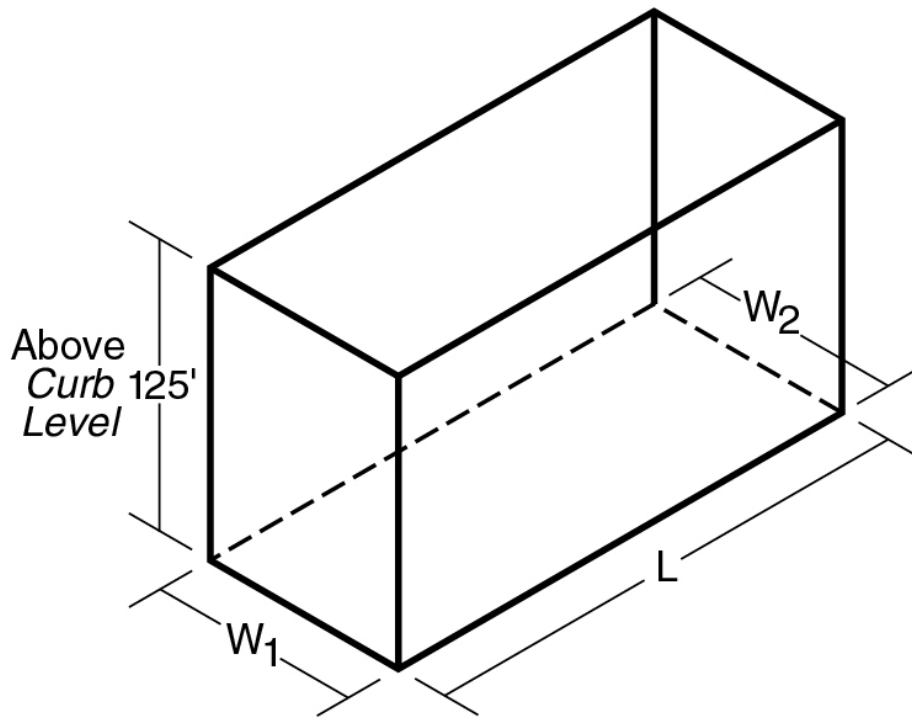

L - Sidewall and prolongation of existing *building*

W₁ - *Front lot line*

W₂ - *Rear wall of existing building*

EXISTING BUILDING VOLUME FOR

MODIFICATION OF STREET WALL REQUIREMENTS

- (b) The City Planning Commission may authorize modifications in the required #street wall# location if the Commission finds that the existing #buildings#, or existing open areas serving existing #buildings# to remain on the #zoning lot#, would be adversely affected by the location of the #street walls# of the #development#, #enlargement# or alteration in a manner prescribed in paragraph (a) of this Section.