



Zoning Resolution

THE CITY OF NEW YORK

Eric Adams, Mayor

CITY PLANNING COMMISSION

Daniel R. Garodnick, Chair

81-265 - Encroachment limitations by length and height rules

File generated by <https://zr.planning.nyc.gov> on 2/5/2025

81-265 - Encroachment limitations by length and height rules

LAST AMENDED

4/28/1988

Above the maximum height of a front wall at the #street line# as set forth in Section [81-262](#), a #building# may only encroach beyond the #half-setback line# if it complies with the provisions of this Section and if the area of #compensating recess# equals or exceeds the area of #encroachment# in #Zone B# and #Zone C# in accordance with the provisions of Section [81-264](#) (Encroachments and compensating recesses).

(a) Special limitations

No #encroachment# beyond the #half-setback line# shall be within 30 feet of a #side lot line#. (See illustration of Prohibited and Allowed Encroachment Beyond Half-Setback Line)

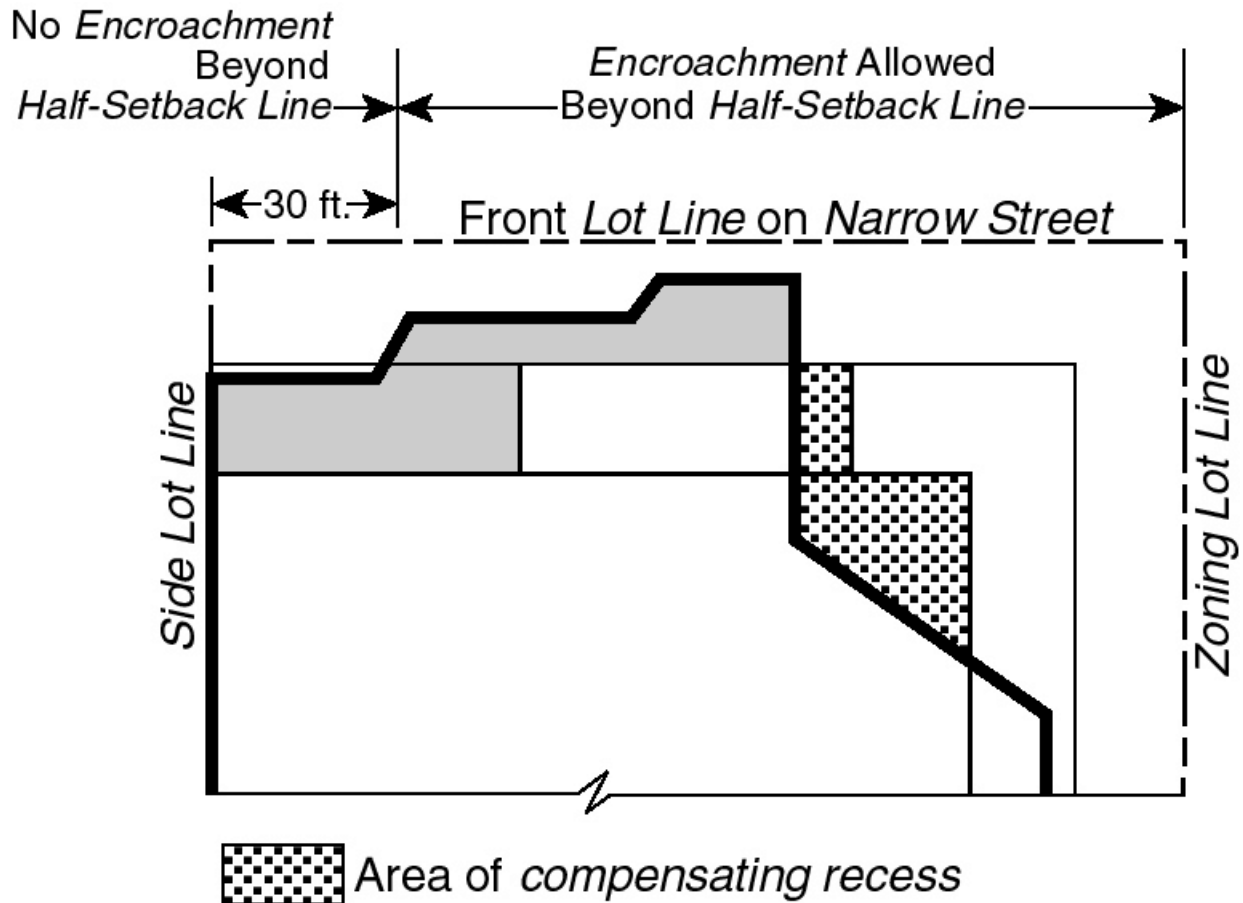

PROHIBITED AND ALLOWED ENCROACHMENT BEYOND

HALF-SETBACK LINE

(81-265a)

(b) General provisions

The length, depth, height and area of #encroachments# along any #street# frontage all contribute to a #building's# impact on daylight access. In order to determine whether the depth of a #building's# #encroachment# into #Zone C# is

justified, the length of the #encroachment#, measured parallel to the #street line#, and its height above #curb level# must also be evaluated. The extent of #encroachment# also must be considered in relation to the extent of the area of #compensating recess# in the same #street frontage zone#. The purpose of the length and height rule is to ensure, in the case of #encroachments# beyond the #half-setback line#, that the closer a #building# comes to the #street line#, the less will be the length of its #encroachment#, its height or both. (See illustration of Elements Analyzed)

The elements comprising this analysis are represented by symbols and are as follows:

(1)

De	=	depth of #encroachment#
D		depth of #setback line#

De (depth of #encroachment#) means depth of #encroachment# beyond the #setback line#. Depth of #encroachment# is measured perpendicularly to the #setback line#.

D (depth of #setback line#) means depth of #setback line# from the #street line# or depth of #ten-foot setback line# from the #street line#, whichever depth is greater.

(2)

Le	=	length of #encroachment#
L		length of #front lot line#

Le (length of #encroachment#) means total length of #encroachment# outside the #half-setback line#. Length of #encroachment# is measured as the total length of the #encroachments#' projections on the #street line#.

L (length of #front lot line#) means the length of the #front lot line# along the particular #street#. However, the length of the #front lot line# for the purposes of this Section shall not exceed 300 feet, irrespective of the actual #lot line# length.

(3)

Le	=	length of #encroachment#
Lr		length of recess

Le (length of #encroachment#) as defined in paragraph (b)(2) of this Section.

Lr (length of recess) means total length of #setback line# not encroached upon by a #building#.

(4)

H	=	height of #encroachment#
L		length of #front lot line#

H (height of #encroachment#) means the height of the #encroachment# above #curb level#.

L (length of #front lot line#) as defined in paragraph (2) of this Section.

(5)

Ar	=	area of #compensating recess#
Ae		area of #encroachment#

Ar (area of #compensating recess#) means area of #compensating recess# in the particular #street frontage zone#. Area of #compensating recess# is calculated to a depth of 100 feet from the #street line#.

Ae (area of #encroachment#) means area of #encroachment# beyond the #setback line#. Area of #encroachment# is calculated to a depth of 100 feet from the #street line#.

Values for the elements in paragraphs (b)(1) through (b)(5) shall be found for each #street frontage zone# on which there is any #encroachment# beyond the #half-setback line#.

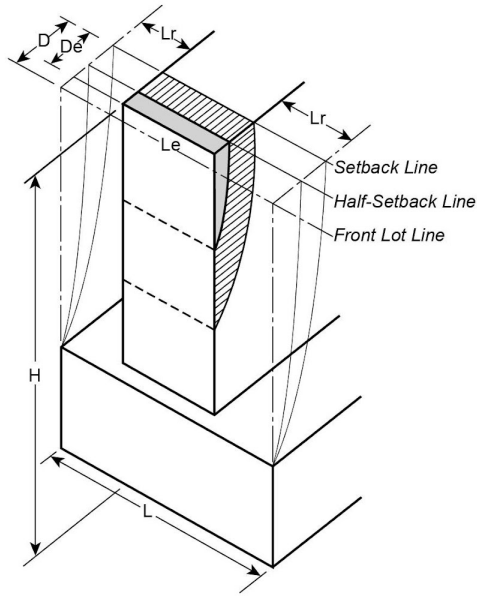

- L – Length of *front lot line* along the particular *street*
- Le – Length of *encroachment* outside *half-setback line* or *ten-foot setback line*
- Lr – Total length of *setback line* not encroached by *building*
- De – Depth of *encroachment*
- D – Depth of *setback line*
- H – Height of *encroachment* above *curb level*

ELEMENTS ANALYZED

(81-265b)

The elements, weighted according to the effects on daylight access, are represented in the formulas and charts that control the depth, length and height of #encroachments#, as set forth in paragraph (c) of this Section.

#Encroachments# of proposed #buildings# or #enlargements# beyond the #half-setback line# are permitted only if in compliance at every point with the formulas in paragraph (c) of this Section. Aside from this general requirement, specified points at which the length, depth, height and area rules shall be applied are presented in paragraphs (d) and (e) of this Section.

(c) #Encroachment# limitations by Formulas 1 and 2

Where applicants elect to have their #buildings# regulated by the formulas, #buildings# shall comply with both Formula 1 and Formula 2 as set forth in this paragraph. Elements of the formulas and the symbols by which they are represented are as set forth in paragraph (b) of this Section.

Formula 1:	Maximum	H	=	5.5—4	(De	—2.5	(Le)
		L				D			L	

Formula 2:

Minimum		Lr	=	L
				3.5

The maximum height of #encroachment# (H) allowed by Formula 1 may be modified for certain conditions, as follows:

- (1) For short frontages

For any frontage less than 200 feet in length, the maximum

H
L

found by applying Formula 1 may be increased by the following multiplier:

2	—	L
		200

- (2) For large areas of #compensating recess#

To the extent that the aggregate area of #compensating recess# (Ar) exceeds the aggregate area of #encroachment# (Ae), the maximum

(H)
	L	

found by applying Formula 1 may be increased by the following multiplier:

1	+	.067 Ar
		Ae

For the purposes of this modification, the measurement of the area of #compensating recess# (Ar) and the area of #encroachment# (Ae) in each particular #street frontage zone# shall be made on the #encroachment grid# at the height level for which #encroachments# beyond the #half-setback line# are checked. The #encroachment grid# shall include all #street frontage zones#. (Ar) shall include all areas of #compensating recess# in the particular #street frontage zone#, whether or not connected, and (Ae) shall include all #encroachments# in both #Zone B# and #Zone C# in the same #street frontage zone#, whether or not such #encroachments# are connected.

(d) Measurement of encroachments

The points at which the formulas are applied will depend upon the shape and dimensions of the encroachments beyond the half-setback line and shall be in accordance with the provisions of this paragraph and paragraph (e) of this Section.

Where the encroachments along a single street frontage are not connected outside the half-setback line, each encroachment shall be measured separately in accordance with the provisions of paragraph (e). However, at any given height, where such non-contiguous encroachments occur, the encroachments shall be examined together, and the length of encroachment (Le) shall be the total of the (Le) for the individual encroachments. (See illustration of Non-contiguous Encroachments)

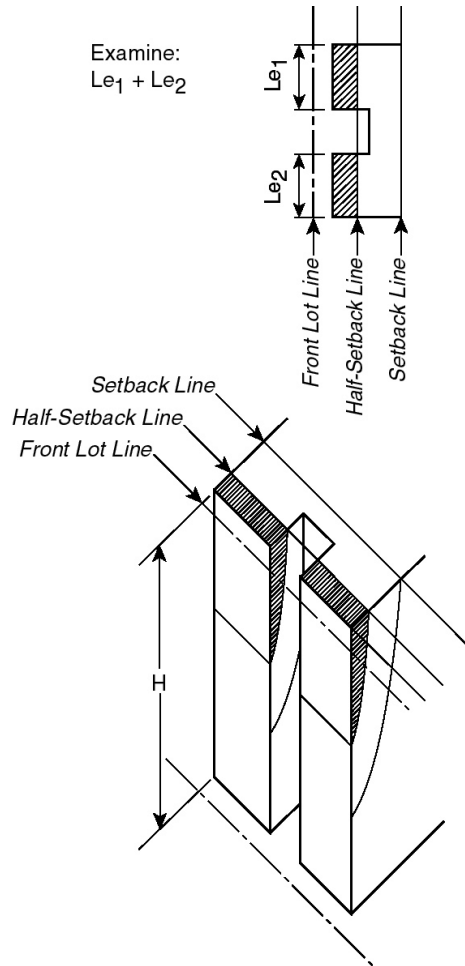

NON-CONTIGUOUS ENCROACHMENTS

(81-265d)

(e) Heights and depths at which formulas are applied

Heights and depths at which the formulas shall be applied are set forth in this paragraph. In addition to meeting the requirements of paragraphs (e)(1) and (e)(2) of this Section, the applicant shall demonstrate that there is no height at which the proposed building or enlargement fails to comply with the formulas in paragraph (c) of this Section.

(1) Standard requirement where length of encroachment is uniform

Where the length of the encroachment (Le) is uniform for the entire height of the encroachment (H) and

the entire depth (D_e) at every height, the length, depth and height rules expressed in the formulas shall be applied only at the height where (D_e/D) is greatest and at the outermost edge of the #encroachment#. (See illustration of Uniform Length of #Encroachment#)

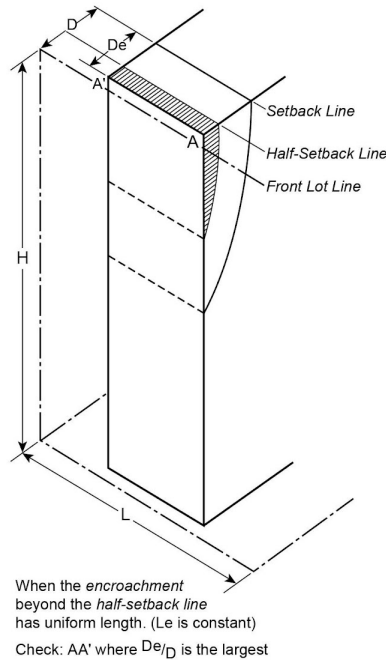

UNIFORM LENGTH OF ENCROACHMENT

(81-265e1)

- (2) Standard requirement where length of #encroachment# is not uniform

Where the length of the #encroachment# (L_e) is not uniform, the rules shall be applied at the height level where (D_e/D) is greatest and also at the height level where the length of #encroachment# (L_e) is greatest. If the greatest length of #encroachment# is uniform for part of the #building's# height, the rules shall be applied at the highest level at which such greatest length of #encroachment# occurs. (See illustrations Where Length of #Encroachment# Is Not Uniform).

If for a particular height level, the length of the #encroachment# (L_e) varies with the depth of the #encroachment# (D_e), the largest (L_e) of this #encroachment# shall be used together with the largest (D_e) in applying the rules as if the #encroachment# were of uniform length as provided in paragraph (e)(1) of this Section.

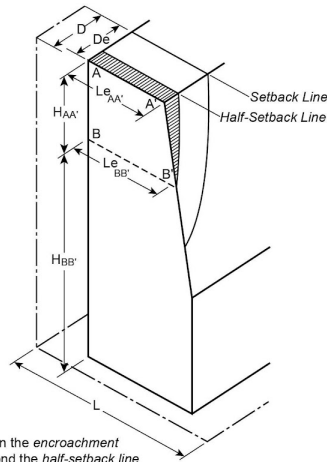

When the encroachment beyond the half-setback line has variable lengths
 Check: AA' where D_e/D is largest
 BB' where L_e/L is largest

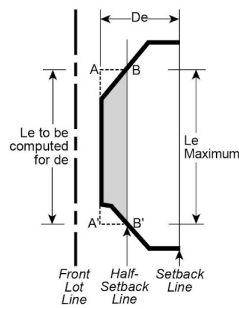

WHERE LENGTH OF ENCROACHMENT IS NOT UNIFORM

(81-265e2)

(f) Encroachments by existing buildings

When a zoning lot contains an existing building which encroaches beyond a half-setback line or a ten-foot setback line, an enlargement or development on such zoning lot shall comply with the following provisions:

(1) Existing buildings below specified heights

(i) Except as provided in paragraph (f)(1)(ii) of this Section, an existing building not more than 120 feet in height shall not be considered in applying the length and height rules even though a portion of such building encroaches beyond the half-setback line or ten-foot setback line along a 60 foot wide street and an existing building not more than 150 feet in height shall not be considered in applying the length and height rules even though a portion of such building encroaches beyond the half-setback line or ten-foot setback line along a street 75 or more feet in width.

(ii) However, the area occupied by the existing building shall be included in the calculation of (A_r/A_e) for the modification of Formula 1 allowed in the case of large areas of compensating recess, as set forth in paragraph (c)(2) of this Section.

(2) Existing buildings above specified heights

Where an existing building more than 120 feet in height encroaches beyond the half-setback line or ten-

foot setback line# along a 60-foot wide #street# or where an existing #building# more than 150 feet in height encroaches beyond the #half-setback line# or #ten-foot setback line# along a #street# 75 or more feet in width, the following provisions, in addition to those of paragraph (d)(3) of Section [81-264](#) (Encroachments and compensating recesses), shall apply:

- (i) no new construction on the #zoning lot# shall encroach beyond the #half-setback line# along any #street#, and
- (ii) the length and height rules of this Section shall not apply.