



Zoning Resolution

THE CITY OF NEW YORK

Eric Adams, Mayor

CITY PLANNING COMMISSION

Daniel R. Garodnick, Chair

95-033 - Location of transit easements

File generated by <https://zr.planning.nyc.gov> on 11/21/2024

95-033 - Location of transit easements

LAST AMENDED

11/30/2017

The transit easement volume may be located within a #building#, in open areas, including #public plazas#, or in areas covered by projected overhangs of a #building#. At least one vertical face of the easement volume shall be at a #front lot line#. The easement volume shall be located on the #zoning lot# as close as possible to the #street# containing the transit line.

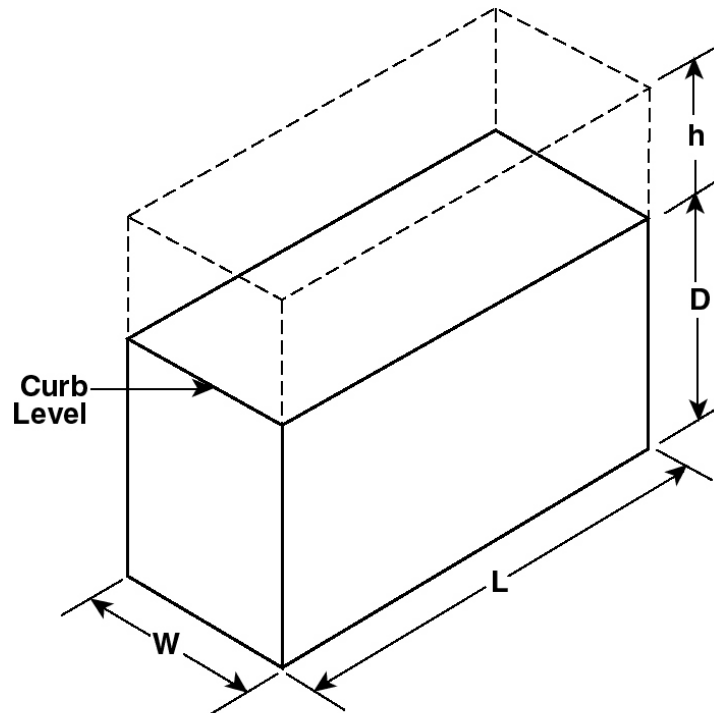

h – Height above curb level

D – Depth below curb level

L – Length

W – Width

TRANSIT EASEMENT VOLUME

([95-032](#))