



Zoning Resolution

THE CITY OF NEW YORK

Eric Adams, Mayor

CITY PLANNING COMMISSION

Daniel R. Garodnick, Chair

33-432 - In other Commercial Districts

File generated by <https://zr.planning.nyc.gov> on 2/22/2025

33-432 - In other Commercial Districts

LAST AMENDED
12/5/2024

C1-6 C1-7 C1-8 C1-9 C2-6 C2-7 C2-8 C3 C4 C5 C6 C8

In the districts indicated, the maximum height of a front wall and the required front setback of a #building or other structure#, except as otherwise set forth in this Section, shall be as set forth in the following table:

MAXIMUM HEIGHT OF FRONT WALL AND REQUIRED FRONT SETBACKS

#Initial Setback Distance# (in feet)		Maximum Height of a Front Wall or other portion of a #Building or Other Structure# within the #Initial Setback Distance#	#Sky Exposure Plane#				
			Height above the #Street Line# (in feet)	Slope over #Zoning Lot# (Expressed as a Ratio of Vertical Distance to Horizontal Distance)			
On #Narrow Street#	On #Wide Street#			On #Narrow Street#		On #Wide Street#	
			Vertical Distance	Horizontal Distance	Vertical Distance	Horizontal Distance	
Within C3 C4-1 C8-1 Districts							
20	15	30 feet or two #stories#, whichever is less	30	1	to 1	1	to 1
Within C1-6 C2-6 C4-2 C4-3 C4-4 C4-5 C8-2 C8-3 Districts							
20	15	60 feet or four #stories#, whichever is less	60	2.7	to 1	5.6	to 1
Within C1-7 C1-8 C1-9 C2-7 C2-8 C4-2F C4-6 C4-7 C4-8 C4-9 C4-11 C4-12 C5 C6 C8-4 Districts							

20	15	85 feet or six #stories#, whichever is less	85	2.7	to 1	5.6	to 1
----	----	---	----	-----	------	-----	------

However, in accordance with the provisions of Section [32-42](#) (Location within Buildings), in C1, C2 or C3 Districts, no #commercial building#, or portion thereof, occupied by non-#residential uses# listed under Use Groups VI through X shall exceed in height 30 feet or two #stories#, whichever is less.

In C4-1 or C8-1 Districts, for #community facility buildings# or #buildings# used for both #community facility# and #commercial# #use#, the maximum height of a front wall shall be 35 feet or three #stories#, whichever is less, and the height above #street line# shall be 35 feet.

In C1-6, C2-6, C4-4 or C4-5 Districts, for #community facility buildings# or #buildings# used for both #community facility# and #commercial# #use#, the maximum height of a front wall shall be 60 feet or six #stories#, whichever is less.

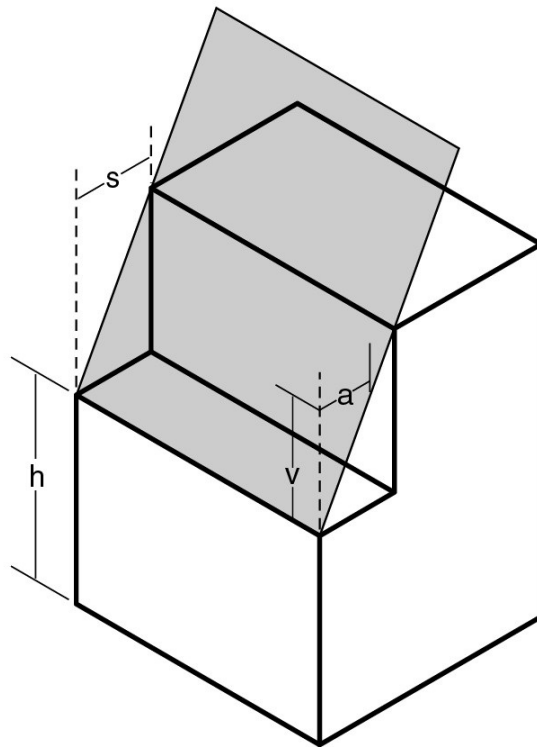

a - Horizontal distance s - Initial setback distance
h - Height of sky exposure plane above street line v - Vertical distance

 Sky Exposure Plane

SKY EXPOSURE PLANE IN OTHER COMMERCIAL DISTRICTS

(23 - 632, 24 - 522, 33 - 432, 43 - 43)